

# THE WAY OF DIGITAL TRANSFORMATION

5G  
PRODUCTS

i2i 5G MOBILE PRIVATE NETWORK

5G MPN

info@i2i-systems.com  
www.i2i-systems.com

 **i2i Systems**  
innovation to integration

# About i2i Systems

i2i Systems is an international information technology company that specializes in developing innovative ideas and solutions. With its highly experienced team in the Telecommunications industry it offers a diverse variety of products in Telco OSS/BSS domains, as well as 5G network solutions.

i2i Systems delivers Next Generation Converged Revenue Management solutions enabling CSPs to unlock new business models, mitigate competition, reduce costs, and quickly monetize new use cases. This is being achieved through systems that are fully convergent, cloud-native, API-first, interoperable, low-code / no-code and modular. The offerings are highly scalable and support subscriber bases ranging from tens of thousands to tens of millions, harmoniously. i2i Systems improves its experience and skills by adapting new technologies and investing in research and development to provide best quality, efficient and visionary products to its customers. In accordance with its disruptive vision, i2i Systems further invests in 5G core-network, offering an end-to-end integrated cloud-based BSS and Network solution for optimizing and converging Service Providers IT and Network landscape thus increasing efficiency and enabling new revenue streams.

## Our Customers – Telecom (CSP) & Industry



## Partners



# i2i 5G MOBILE PRIVATE NETWORK

## The Foundation of Digital Transformation

In the era of Industry 4.0, businesses seeking to maximize production efficiency must embrace digital transformation.

With i2i's **5G Mobile Private Network (MPN)** solution, enterprises move beyond simple connectivity into real-time operational intelligence. The **i2i 5G Core (5GC)** in the solution delivers deterministic performance, ultra-low latency, and carrier-grade reliability. Its cloud-native, highly available, stateless, and secure architecture is specifically tailored to meet demanding enterprise KPIs. Built on 3GPP Rel. 18 standards, the i2i 5G Core ensures seamless interoperability with any 3GPP-compliant RAN vendor, eliminating vendor lock in.

By seamlessly integrating wearable devices, industrial IoT sensors, robotics, and AI-powered video analytics, the i2i MPN transforms operational environments into data driven, autonomous ecosystems.

### **i2i MPN enables:**

#### **Autonomous Systems**

Low-latency communication ensures deterministic control for AGVs, AMRs, robotic arms, and drones supporting precision navigation, collision avoidance, and coordinated fleet orchestration in dynamic industrial environments.

#### **Industrial Automation & OT Convergence**

Secure integration with PLCs, SCADA, MES, and robotic controllers enables real-time synchronization across production lines. 5G replaces fragmented wired and Wi-Fi infrastructures with a unified, resilient wireless backbone.

#### **Enhanced Operational Visibility**

High-definition video streaming combined with edge-based AI analytics delivers instant anomaly detection, quality inspection, perimeter security, and real-time asset tracking, reducing downtime and improving safety compliance.

#### **Extended Reality (AR/VR/XR)**

High-throughput, low-latency connectivity supports immersive AR/VR applications for remote maintenance, digital twins, and expert-assisted operations, minimizing travel costs and accelerating workforce training.

#### **AI-Driven Decision Intelligence**

Edge computing capabilities enable real-time data processing at the source, transforming raw operational data into actionable insights which is improving throughput, predictive maintenance, and energy efficiency.

# i2i 5G MPN - SNPN Deployment Model

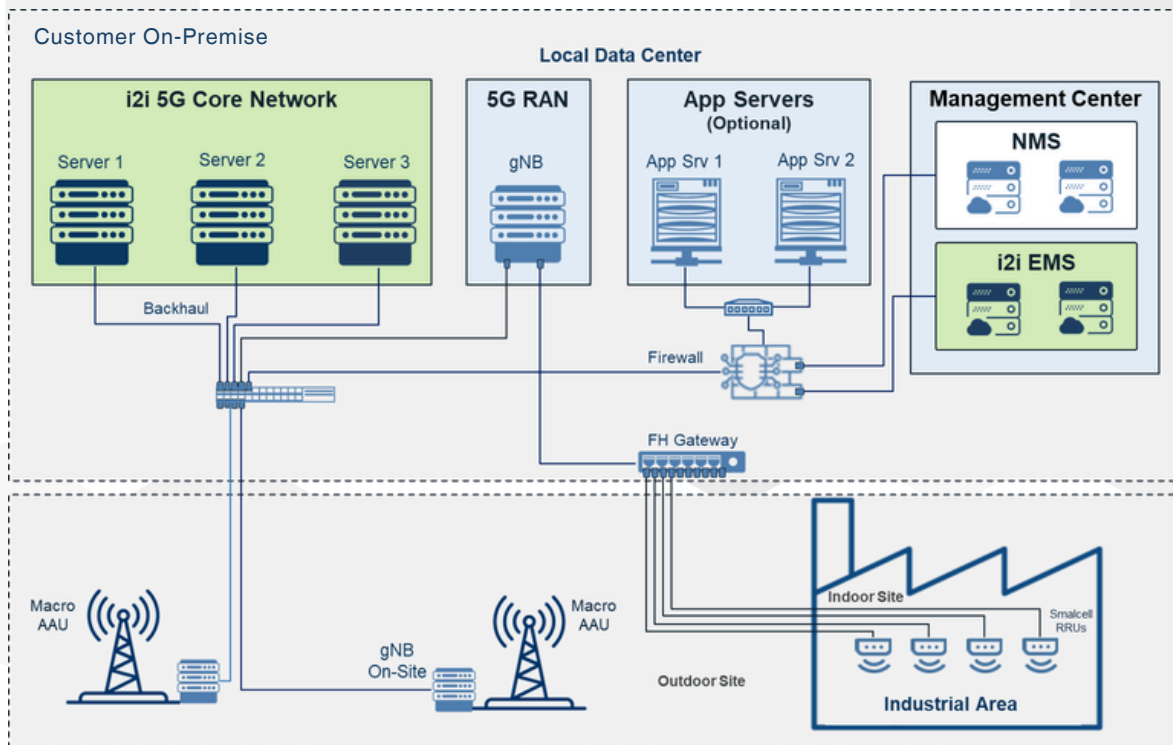

## i2i MPN Operations Center

The heart of the i2i solution is our Operations Center, featuring a **3GPP Rel. 18** compliant, **cloud-native i2i 5G Core (5GC)** Network Functions (AMF, SMF, UPF, and all required NFs) and a robust **i2i Element Management System (EMS)**. We offer three flexible deployment models:

- 1. On-Premise SNPN (Standalone Private 5G) Deployment:** A fully independent core established within your local facility for maximum data autonomy, sovereignty, and localized control.
- 2. Centralized Deployment:** High-tier connectivity via a multi-tenant Operations Center designed for reduced CapEx and simplified, remote network management.
- 3. Hybrid Deployment:** Mission-critical components (such as the User Plane Function - UPF) are deployed at the edge for ultra-low latency, while control functions remain centralized for operational efficiency.

# i2i 5G MPN - Hybrid Deployment Model

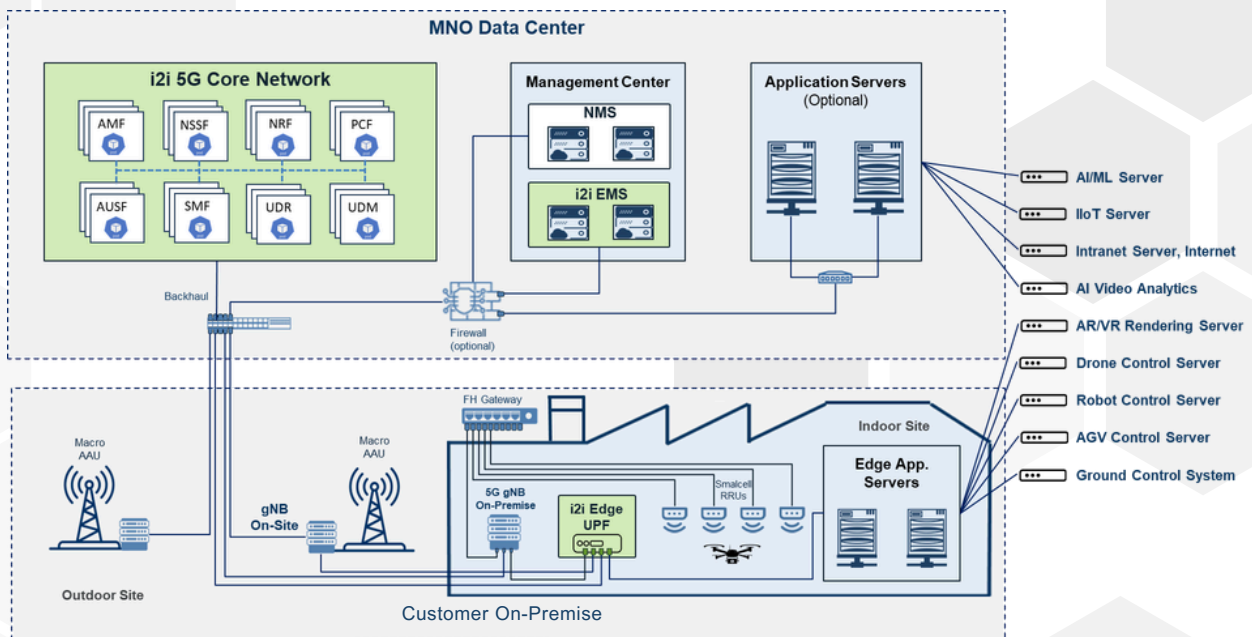

## The 5G Advantage: Performance Guaranteed

The i2i MPN infrastructure is engineered to meet the most demanding industrial KPIs:

- **Ultra-Low Latency:** Essential for real-time remote management and mission-critical robotics (sub-1ms latency on UPF and sub-10ms overall response time).
- **High Capacity & Bandwidth:** Supports massive number of devices in a small geographic area and high throughput (up to 100 Gbps), assuming sufficient gNBs are deployed.
- **Multi-Access Edge Computing (MEC):** Strategic data processing via Local (On-Premise) or Distributed Cloud Compute based on your specific application needs.
- **Private & Secure Coverage:** Guaranteed, reserved capacity that ensures your IoT ecosystem remains isolated from public network congestion and security threats.

The **i2i MPN** provides dedicated coverage within a defined geographical area, ensuring exclusive and secure access for your organization.

## Empowering the 5G Era: i2i Systems Drives Innovation and Efficiency with Red Hat OpenShift AI

i2i Systems' 5G Core Network provides increased productivity and operational efficiency through Red Hat OpenShift AI, which enables intelligent automation, real-time analytics, and adaptive resource management. AI is poised to accelerate the delivery of innovative new experiences while significantly improving business processes and resource utilization, empowering i2i Systems to thrive in the 5G era.



## ● Head Quarter Office

Yıldız Teknik Üniversitesi Davutpaşa  
Kampüsü Teknoloji Geliştirme Bölgesi D-2  
Blok K:1 No:Z-08 Esenler, İstanbul, Türkiye

☎ +90 212 285 48 44

📍 [Get Directons](#)

## ● YTÜ Teknopark R&D Center

Yıldız Teknik Üniversitesi Davutpaşa Kampüsü  
Teknoloji Geliştirme Bölgesi D-2 Blok K:1 No:Z-  
08 Esenler, İstanbul, Türkiye

☎ +90 212 285 48 44

📍 [Get Directons](#)

## ● Teknopark Istanbul R&D Center

Sanayi Mah. Teknopark Bulvarı, Teknopark  
İstanbul C1 Blok 9. Kat No:1901-1902 Kurtköy,  
Pendik, İstanbul, Türkiye

☎ +90 212 285 48 44

📍 [Get Directons](#)

info@i2i-systems.com

www.i2i-systems.com

 **i2i Systems**  
innovation to integration